

Pump Specification

XFL50-Series

1/2 hp Submersible Effluent Pumps for Hazardous Locations

*Class 1, Division 1, Groups C and D
Class 1, Zone 1, Groups IIA and IIB*

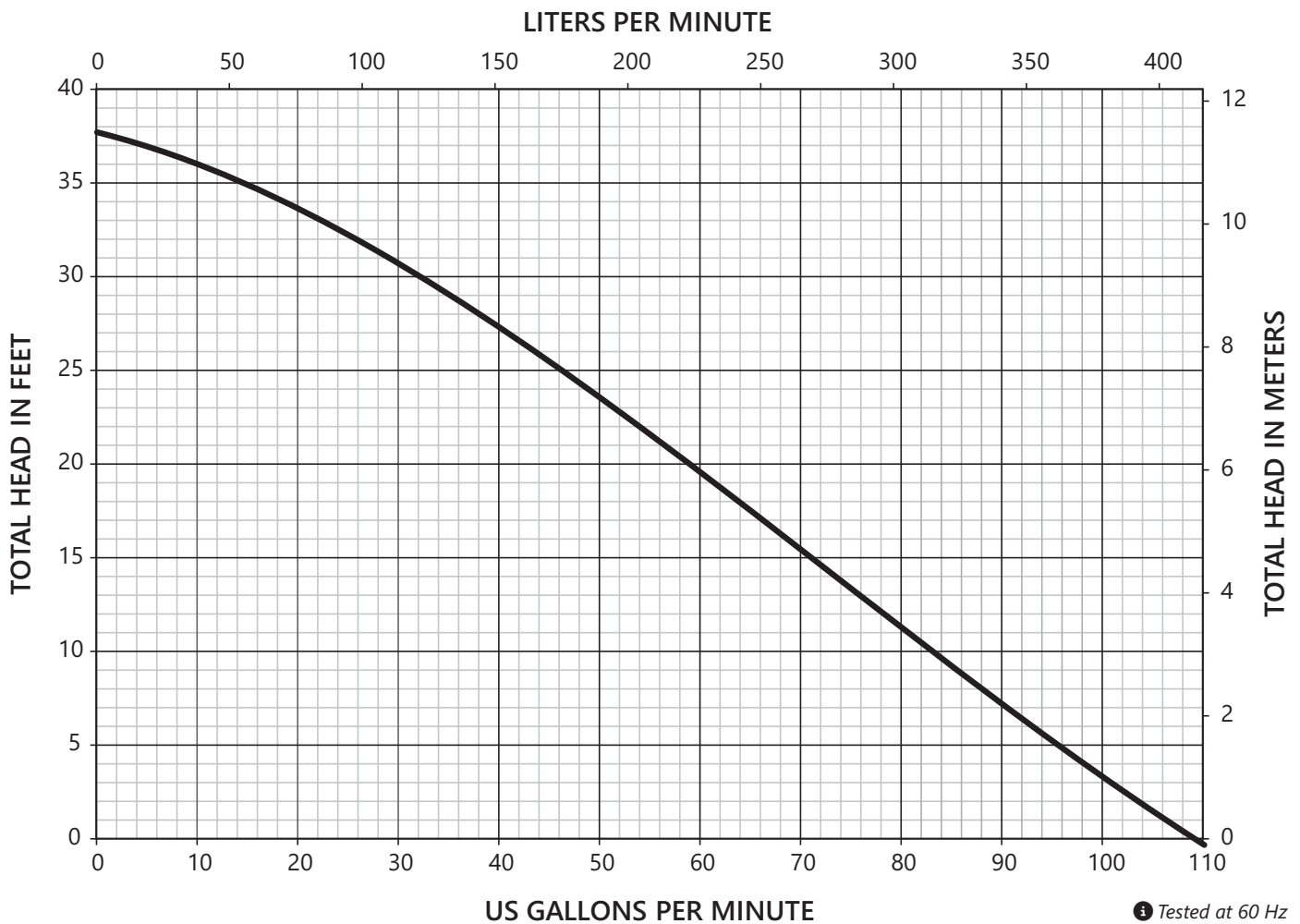
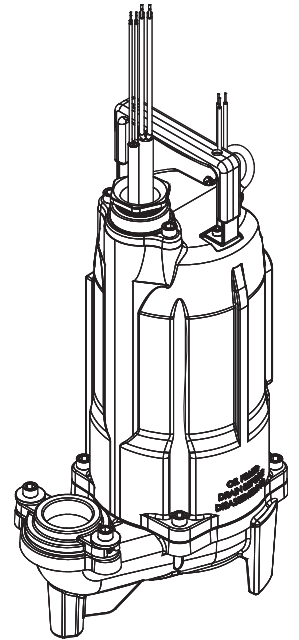

XFL50-Series Dimensional Data

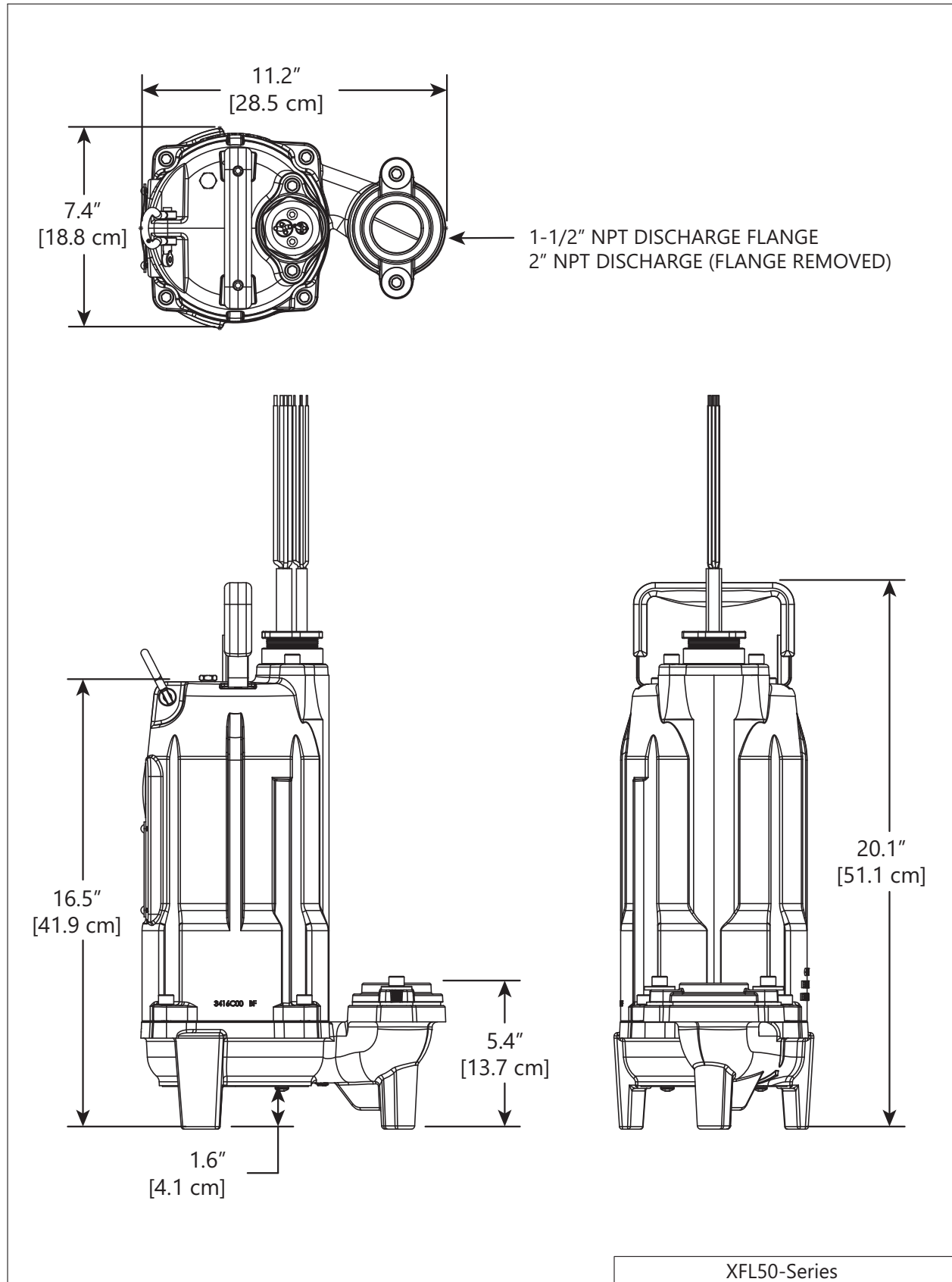

XFL50-Series Electrical Data

MODEL	HP	IMPELLER	VOLTAGE	PHASE	FULL LOAD AMPS	LOCKED ROTOR AMPS	THERMAL OVERLOAD TEMP	STATOR WINDING CLASS	CORD LENGTH [FT]	DISCHARGE NPT
XFL51M-2	1/2	CAST IRON	115	1	14	66	120°C / 248°F	F	25	1-1/2" OR 2"
XFL51M-3	1/2	CAST IRON	115	1	14	66	120°C / 248°F	F	35	1-1/2" OR 2"
XFL51M-5	1/2	CAST IRON	115	1	14	66	120°C / 248°F	F	50	1-1/2" OR 2"
XFL52M-2	1/2	CAST IRON	208/230	1	7	33.6	105°C / 221°F	F	25	1-1/2" OR 2"
XFL52M-3	1/2	CAST IRON	208/230	1	7	33.6	105°C / 221°F	F	35	1-1/2" OR 2"
XFL52M-5	1/2	CAST IRON	208/230	1	7	33.6	105°C / 221°F	F	50	1-1/2" OR 2"
XFL53M-2	1/2	CAST IRON	208/230	3	4.5	33.5	105°C / 221°F	F	25	1-1/2" OR 2"
XFL53M-3	1/2	CAST IRON	208/230	3	4.5	33.5	105°C / 221°F	F	35	1-1/2" OR 2"
XFL53M-5	1/2	CAST IRON	208/230	3	4.5	33.5	105°C / 221°F	F	50	1-1/2" OR 2"
XFL54M-2	1/2	CAST IRON	440-480	3	2.6	33.5	105°C / 221°F	F	25	1-1/2" OR 2"
XFL54M-3	1/2	CAST IRON	440-480	3	2.6	33.5	105°C / 221°F	F	35	1-1/2" OR 2"
XFL54M-5	1/2	CAST IRON	440-480	3	2.6	33.5	105°C / 221°F	F	50	1-1/2" OR 2"
XFL55M-2	1/2	CAST IRON	575	3	2.2	12.8	105°C / 221°F	F	25	1-1/2" OR 2"
XFL55M-3	1/2	CAST IRON	575	3	2.2	12.8	105°C / 221°F	F	35	1-1/2" OR 2"
XFL55M-5	1/2	CAST IRON	575	3	2.2	12.8	105°C / 221°F	F	50	1-1/2" OR 2"

MODEL	HP	IMPELLER	VOLTAGE	PHASE	FULL LOAD AMPS	LOCKED ROTOR AMPS	THERMAL OVERLOAD TEMP	STATOR WINDING CLASS	CORD LENGTH [FT]	DISCHARGE NPT
XFL51BM-2	1/2	BRONZE	115	1	14	66	120°C / 248°F	F	25	1-1/2" OR 2"
XFL51BM-3	1/2	BRONZE	115	1	14	66	120°C / 248°F	F	35	1-1/2" OR 2"
XFL51BM-5	1/2	BRONZE	115	1	14	66	120°C / 248°F	F	50	1-1/2" OR 2"
XFL52BM-2	1/2	BRONZE	208/230	1	7	33.6	105°C / 221°F	F	25	1-1/2" OR 2"
XFL52BM-3	1/2	BRONZE	208/230	1	7	33.6	105°C / 221°F	F	35	1-1/2" OR 2"
XFL52BM-5	1/2	BRONZE	208/230	1	7	33.6	105°C / 221°F	F	50	1-1/2" OR 2"
XFL53BM-2	1/2	BRONZE	208/230	3	4.5	33.5	105°C / 221°F	F	25	1-1/2" OR 2"
XFL53BM-3	1/2	BRONZE	208/230	3	4.5	33.5	105°C / 221°F	F	35	1-1/2" OR 2"
XFL53BM-5	1/2	BRONZE	208/230	3	4.5	33.5	105°C / 221°F	F	50	1-1/2" OR 2"
XFL54BM-2	1/2	BRONZE	440-480	3	2.6	33.5	105°C / 221°F	F	25	1-1/2" OR 2"
XFL54BM-3	1/2	BRONZE	440-480	3	2.6	33.5	105°C / 221°F	F	35	1-1/2" OR 2"
XFL54BM-5	1/2	BRONZE	440-480	3	2.6	33.5	105°C / 221°F	F	50	1-1/2" OR 2"
XFL55BM-2	1/2	BRONZE	575	3	2.2	12.8	105°C / 221°F	F	25	1-1/2" OR 2"
XFL55BM-3	1/2	BRONZE	575	3	2.2	12.8	105°C / 221°F	F	35	1-1/2" OR 2"
XFL55BM-5	1/2	BRONZE	575	3	2.2	12.8	105°C / 221°F	F	50	1-1/2" OR 2"

XFL50-Series Control Panel Information

Liberty Pumps ISS and ISD-Series panels include intrinsically safe float circuits for use with pumps in hazardous locations.

PUMP MODELS	CAPACITOR	CAP KIT	ISS-SERIES SIMPLEX PANEL	ISD-SERIES DUPLEX PANEL
XFL51	50 μ F	K001515	ISS24LC1=3-5	ISD24LC2=3-5
XFL52	45 μ F	K001514	ISS24LC1=3-5	ISD24LC2=3-5
XFL53	N/A	N/A	ISS34=3-171-5	ISD34=3-171-5
XFL54	N/A	N/A	ISS34=3-141-5	ISD34=3-141-5
XFL55	N/A	N/A	ISS54=3-121-5	ISD54=3-121-5

XFL50-Series Technical Data

IMPELLER	7 VANE, SEMI-OPEN CLASS 25 CAST IRON OR BRONZE
SOLIDS HANDLING SIZE	3/4"
PAINT	POWDER COATING
MAX LIQUID TEMP	40°C / 104°F CONTINUOUS DUTY
MAX STATOR TEMP	130°C / 266°F
THERMAL OVERLOAD	105°C / 221°F
POWER CORD TYPE	SOOW
MOTOR HOUSING	CLASS 30 CAST IRON
VOLUTE	CLASS 30 CAST IRON
SHAFT	STAINLESS
HARDWARE	STAINLESS
O-RINGS	BUNA-N
MECHANICAL SEAL UPPER	UNITIZED GRAPHITE IMPREGNATED SILICON CARBIDE
MECHANICAL SEAL LOWER	2 PIECE – SILICON CARBIDE / SILICON CARBIDE
MIN BEARING LIFE	50,000 HRS
WEIGHT	40.4 KG / 89 LBS
CERTIFICATIONS	SSPMA, cCSAus (60 HZ MODELS ONLY)

XFL50-Series Specifications

1.01 GENERAL

The contractor shall provide labor, material, equipment, and incidentals required to provide _____ (QTY) centrifugal pumps as specified herein. The pump models covered in this specification are XFL50-Series single-phase or three-phase pumps. The pump furnished for this application shall be model _____ as manufactured by Liberty Pumps.

2.01 OPERATING CONDITIONS

Each submersible pump shall be rated at 1/2 hp, _____ volts, _____ phase, 60 Hz, 3450 RPM. The unit shall produce _____ GPM at _____ feet of total dynamic head.

The submersible pump shall be capable of handling residential effluent with 3/4" solid handling capability. The submersible pump shall have the following hydraulic performance: shut-off head of 38 feet and a maximum flow of 96 GPM @ 5 feet of total dynamic head.

The pump shall be controlled with:

_____ A NEMA 4X outdoor simplex control panel with three float switches including a high water alarm

_____ A NEMA 1 indoor simplex control panel with three float switches including a high water alarm

_____ A NEMA 4X outdoor duplex control panel with three float switches including a high water alarm

_____ A NEMA 1 indoor duplex control panel with three float switches including a high water alarm

_____ A NEMA 4X outdoor duplex control panel with four float switches including a high water alarm

_____ A NEMA 1 indoor duplex control panel with four float switches including a high water alarm

Note: Control panels must include intrinsically safe float circuits when pumps are installed in hazardous locations.

3.01 CONSTRUCTION

Each centrifugal effluent pump shall be equal to the  Certified XFL50-Series pumps as manufactured by Liberty Pumps, Bergen NY. The castings shall be constructed of class 30 cast iron. The motor housing shall be oil-filled to dissipate heat. Air-filled motors shall not be considered equal since they do not properly dissipate heat from the motor. All mating parts shall be machined and sealed with Buna-N O-rings. All fasteners exposed to the liquid shall be stainless steel. The upper and lower bearing of the motor shall be capable of handling all radial and thrust loads. The pump is protected with a dual seal configuration with an oil cavity between the two seals. A leak sensor is housed in this chamber to detect the presence of water and will activate an alarm at the control panel indicating service is required. The lower seal is a silicon carbide / silicon carbide with stainless steel housings and spring two piece design to facilitate service. The second / main seal shall be a unitized graphite impregnated silicon carbide hard face seal with stainless steel housings and spring.

4.01 ELECTRICAL POWER CORD

The submersible pump shall be supplied with 25, 35, or 50 feet of a multi-conductor cord of type SOOW, as per ***Electrical Data*** table. The power cord shall be sized for the rated full load amps of the pump in accordance with the National Electric Code®. A separate SOOW control cord of equal length will also exit the pump. Both cords are located within a casting configured for 1-1/2" conduit if the application requires. The cords shall be secured with a rubber seal ring and potted thus preventing any wicking through the conductors.

5.01 MOTORS

Single-phase motors shall be oil-filled, permanent split capacitor, class F insulated, NEMA B design, and rated for continuous duty. Three-phase motors shall be oil-filled, class F insulated, NEMA B design, and rated for continuous duty. At maximum load, the winding temperature shall not exceed 130°C un-submerged. Since air-filled motors are not capable of dissipating heat, they shall not be considered equal. Single-phase pump motors shall have an integral thermal / current overload switch in the windings for protecting the motor. A capacitor is required and shall be mounted in the control panel. Three-phase motors shall have a thermal overload device mounted on the windings that is connected to a motor control relay located in the control panel.

6.01 BEARINGS AND SHAFT

Upper and lower ball bearings shall be required. The bearings shall be a single ball / race type bearing. Both bearings shall be permanently lubricated by the oil that fills the motor housing. The motor shaft shall be made of 300 series stainless steel and have a minimum diameter of 0.625".

7.01 SEALS

The pump shall have two shaft seals with an oil chamber between them. A leak detection probe is positioned in the oil chamber and continuously monitors for water that would indicate the lower seal has failed. The lower seal is a two piece design and can be serviced in the field. The upper is a unitized graphite impregnated silicon carbide hard face seal design. The lower seal is silicon carbide / silicon carbide seal face with stainless steel housings and spring. All other seals are of an O-ring design of Buna-N material.

8.01 IMPELLER

The impeller shall be a class 25 cast iron or bronze, with pump out vanes on the back shroud to keep debris away from the seal area. It shall be threaded onto the motor shaft.

9.01 CONTROLS

All XFL50-Series pumps require a control panel. Single-phase units utilize a permanent split capacitor (PSC) type motor and require a specific run capacitor. Three-phase motors are equipped with a thermal overload that must be connected in the control panel to protect against overheating. Control panels must include intrinsically safe float circuits when pumps are installed in hazardous locations. Panels themselves shall be located outside of the hazardous location, and installed according to all state, local, and federal codes.

10.01 PAINT

The exterior of the casting shall be protected with powder coat paint.

11.01 SUPPORT

The pump shall have cast iron support legs enabling it to be a freestanding unit. The legs shall be high enough to allow 3/4" solids to enter the volute.

12.01 SERVICEABILITY

Components required for the repair of the pump shall be shipped within a period of 24 hours.

13.01 FACTORY ASSEMBLED TANK SYSTEMS WITH GUIDE RAIL AND QUICK DISCONNECT DISCHARGE

- Factory mounted guide rail system with pump suspended by bolt-on quick disconnect, sealed by means of nitrile grommets or O-rings. The discharge piping shall be Schedule 80 PVC and furnished with a check valve and PVC shut-off ball valve. The tank shall be wound fiberglass or roto-molded plastic. An inlet hub shall be provided with the fiberglass systems.
- Stainless steel guide rail
- Zinc plated steel guide rail
- Diameter of basin size in inches
- Height of basin size in inches
- Distance from top of tank to discharge pipe outlet in inches
- Fiberglass cover
- Structural foam polymer cover
- Steel cover
- Simplex system with outdoor panel and alarm
- Duplex system with outdoor panel and alarm
- Simplex system with indoor panel and alarm
- Duplex system with indoor panel and alarm
- Separate outdoor alarm
- Remote outdoor alarm

14.01 TESTING

The pump shall have a ground continuity check and the motor chamber shall be hi-potted to test for electrical integrity, moisture content, and insulation defects. The motor and volute housing shall be pressurized and an air leak decay test performed to ensure integrity of the motor enclosure. The pump shall be monitored for run voltage and current, and checked for noise or other malfunction.

15.01 QUALITY CONTROL

The pump shall be manufactured in an ISO 9001 certified facility.

16.01 WARRANTY

Standard limited warranty shall be 3 years.